

## Description:

The SDX6811N/ SDX6812N are AES audio embedding modules. Both modules can de-embed four channels (two pairs) audio from SD-SDI signal and support reclocked SDI output. The user can choose any channel out of four embedded audio groups as audio output, or choose the synthesized audio as output signal.

Each module has its own distinct feature as follows:

The SDX6811N has unbalanced AES output, and the SDX6812N has balanced AES output.

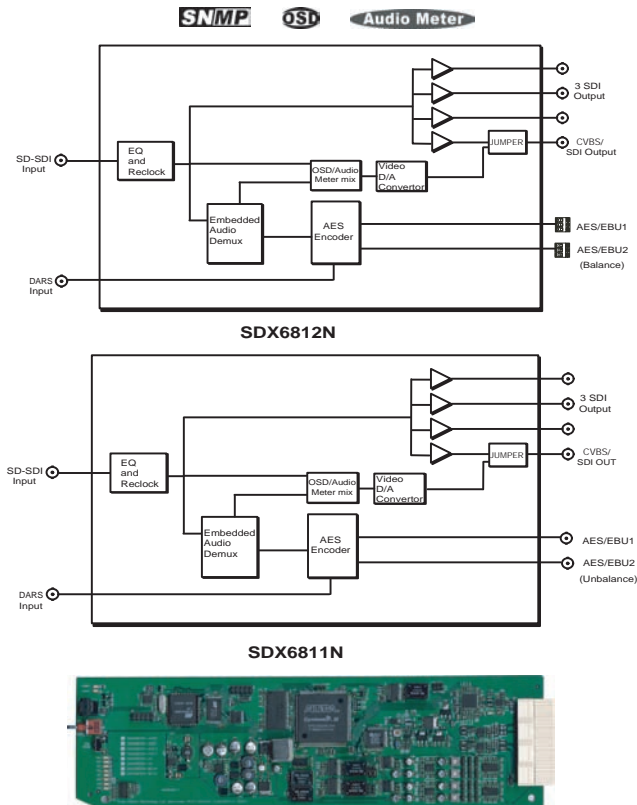

## Features:

- ▶ De-embedding audio from SD-SDI signal; supporting 2 pairs (4 channels) of AES/EBU outputs
- ▶ De-embedding in 525/625 video standard
- ▶ SDI output with equalization and reclocking
- ▶ One channel analog composite output monitoring
- ▶ 27 available signal sources for each audio output
- ▶ SD-SDI video input auto-detect and input status feedback
- ▶ Supporting 16-bit, 20-bit and 24-bit audio processing
- ▶ Supporting 4-channel audio metering display
- ▶ Generating Tone signal at fixed frequency rate
- ▶ Supporting maximum 1.3 seconds audio delay, invert and mute
- ▶ EDH Monitoring
- ▶ Freeze frame, black field and video loss detection
- ▶ Audio loss and audio overload monitoring



SDX6812N

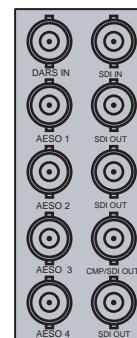

SDX6811N

## Specifications: (Specifications are subject to change without notice)

### SDI Video Input

Standards	SMPTE259M-C; 270 Mbps, 525/625 component
Connector	BNC (IEC 169-8)
Impedance	75 ohm
Return Loss	>18 dB to 270 MHz
Equalization	Auto equalizing to 30dB@270 Mbps

### SDI Video Output

Standards	SMPTE259M-C; 270 Mbps, 525/625 component
Connector	BNC (IEC 169-8)
Impedance	75 ohm
Return Loss	>18 dB to 270 MHz
Signal Level	800 mV +/-10%
DC Offset	0 V +/- 0.5 V
Rise and Fall Time	400-1500 ps (20% to 80% of amplitude)
Overshoot	< 10% of amplitude
Jitter	<0.2 UI (740 ps) (peak to peak)

### Analog Composite Video Output

Standards	NTSC, PAL or PAL-M
Level	1Vp-p +/-3dB
Impedance	75 ohm
Return Loss	>40 dB到5 MHz
DC Offset	0V ± 0.05 V
Frequency Response	±0.2 dB to 5 MHz
Differential Gain	<1%
Differential Phase	<1.5°
Group Delay	+/-10ns to 5 MHz

## SDI Audio Output

**Unbalanced AES Output (applicable to SDX6811N only)**

Connector	BNC (IEC 169-8)
Output Level	1.0 V +/-10% (peak to peak)
DC offset	0.0V ± 50.0mV
Rise and Fall Time	30 to 44 ns (10% to 90% of amplitude)
Impedance	75 ohm
Return Loss	>25 dB, 0.1 to 6.0 MHz

**Balanced AES Output (applicable to SDX6812N)**

Connector	3-pin connector (male)
Output Level	2.0 to 7.0 V (peak to peak)
Jitter	+/-20 ns
Rise and Fall Time	5 to 30 ns (10% to 90%)
Impedance	110 ohm +/- 20% (0.1 to 6 MHz)
CMR Ratio	>30 dB below output signal (0 to 6 MHz)

## DARS Input

**Balanced DARS Input**

Connector	3-pin connector
Sensitivity	< 200mv
Impedance	110 ohm +/- 20% (0.1 to 6 MHz)
Maximum Input Level	10V (peak to peak)
CMR Ratio	>30 dB below output signal (0 to 6 MHz)

**Unbalanced DARS Input**

Connector	BNC (IEC 169-8)
Sensitivity	< 200mv
Impedance	75 ohm
Return Loss	>35 dB, 0.1 to 6.0 MHz

**Power Consumption**

Power	3.25W
Positive Rail	500 mA
Negative Rail	10 mA

**Ordering Information:**

SDX6811N	Unbalanced AES audio de-embedding module	SDX6812N	Balanced AES audio de-embedding module
----------	--	----------	--